

PARTICLE SIZE

PARTICLE SHAPE

POWDER CHARACTERISTICS

A scientist in a white lab coat and glasses is working on a piece of laboratory equipment. The scientist is looking intently at the device, which has a transparent tube and a black component. The background is a plain, light color.

Better Particle Size Solutions
Accelerate Your Business

Bettersize
BETTER PARTICLE SIZE SOLUTIONS



Better Particle Size Solutions

ABOUT BETTERSIZING

Bettersize has been developing and manufacturing laser particle size analysers since 1995. We are a team of ~160 employees dedicated to share our expertise to satisfy your requirements with reliable products and first-class services.

Nowadays, we are more than instrument suppliers; we help to accelerate your business. We use advanced, scientific approaches, collaborate extensively with global research leaders in academia, government and industry to answer questions at the leading edge of particle sizing research. We carry out every production step under our own roof, including key components manufacturing and automated assembly, to anticipate possible failures or manufacturing problems. We provide analysis demonstrations, installation and training, software upgrade, 10-year supply of spare parts, and maintenance services to improve the working efficiency for our product users. We deliver state-of-the-art technological solutions to understand powder material properties, facilitate new product developments, control product quality, and improve manufacturing efficiency in hand with our clients.

For more than 20 years, we have delivered excellence to our business partners. Now, our ambition is to become the leader in particle sizing and powder characterization field, to support companies and laboratories worldwide.

We are Bettersize, better particle size solutions.

PRODUCT SERIES

We have 5 main product series. Each of the series in our portfolio provides you simple, fast, and reliable analysis of powder and particle materials:

- **Bettersizer** - laser particle size analyzer;
- **BeVision** - image particle size and shape analyzer;
- **Nanoptic** - nanoparticle size analyzer;
- **PowderPro** and **BeDensi** - powder characteristics testers.

Particle size ranges and models

Particle size range*	1 nm	10 nm	100 nm	1 µm	10 µm	100 µm	1 mm	3.5 mm	10 mm	
Laser diffraction		Bettersizer S3 Series: 0.01 - 3500 µm								
		Bettersizer 2600: 0.02 - 2600 µm								
			Bettersizer ST: 0.1 - 1000 µm							
DLS (Dynamic light scattering)	Nanoptic series: 1 - 9500 nm									
Dynamic image				BeVision Series: 1 - 10 mm						

*Particle size ranges are sample dependent



Leading Particle Sizing Instruments Manufacturer

CONFORMITY

All series of Battersize instruments have passed **ISO9001** international quality management certification and the European **CE** certification. All laser particle size analysers have obtained the approval of **21 CFR Chapter I Subchapter J, Part 1040.10 and 1040.11**.

The software complies with the **U.S. FDA 21 CFR Part 11**, ensuring the validity and reliability of measurement results and solves the challenges associated with traceability requirements.



CUSTOMERS

With a solid history of over **12,000 instruments** shipped and installed, we understand the importance of customer satisfaction. Battersize is committed to providing customers cutting edge technology and superior services and support.

We are honoured to provide instruments and services to:



INNOVATIVE TECHNOLOGY

As the leading particle sizing instruments manufacturer in China, we spare no efforts on R&D each year. The following patented technologies have been developed and applied to our instruments:

- DLOIOS - Dual Lens and Oblique Incidence Optical System
- Fourier and inverse Fourier optical system
- DLOS - Dual Lens Optical System
- Laser diffraction + dynamic image analysis
- Refractive index measurement
- Online particle size monitor and control
- SOP (Standard Operation Procedure)
- Automatic alignment
- Automatic circulation and dispersion
- Accuracy calibration
- Anti-dry burning protection ultrasonic disperser
- Automatic water supply
- Small volume sample cell assembly
- Real-time test result monitor
- Automatic water level monitor
- Dew point temperature monitor
- Anti-corrosive circulation and dispersion system
- Dry sampling and dispersion

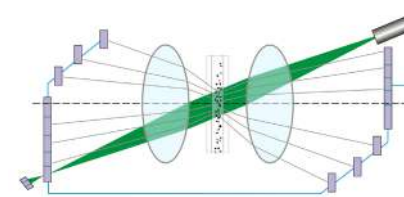

DLOIOS

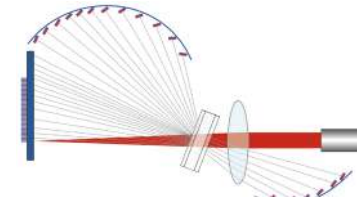

Fourier and inverse Fourier optical system

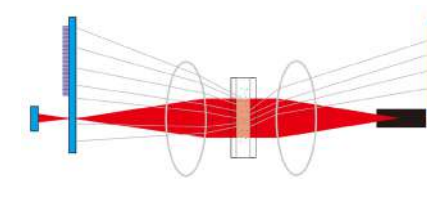

DLOS

APPLICATIONS

Battersize offers a wide range of models that fit different application requirements and provide reliable measurement day-in-day-out.

Our instruments find applications in the following fields:

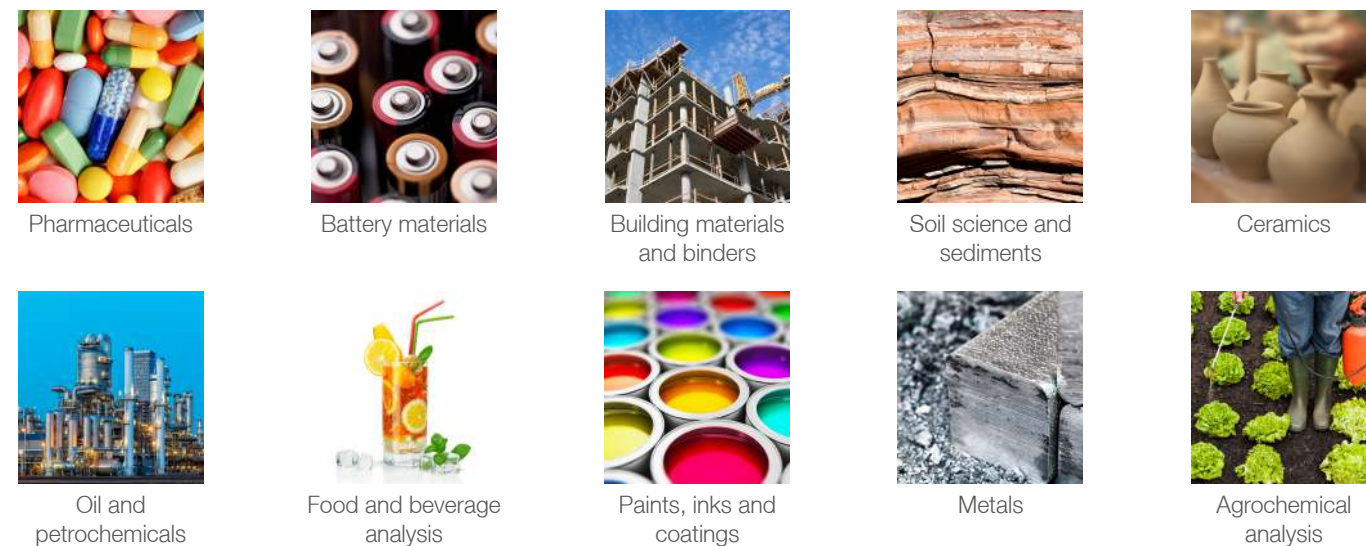

Bettersizer S3 Plus

COMPLETE PARTICLE SIZE AND SHAPE ANALYSIS BY ONE DEVICE

Thanks to its unique and innovative design, the Bettersizer S3 Plus combines the advantages of the measurement methods such as “laser diffraction” and “dynamic image analysis”. It offers a comprehensive and precise characterization of particle size and shape from nanometers to millimeters. The live view of the CCD cameras before and during the measurement allows the user to evaluate the dispersion state of the sample and visually assess the measurement result. All particles above 2 µm were photographed and evaluated online at the request of the user.

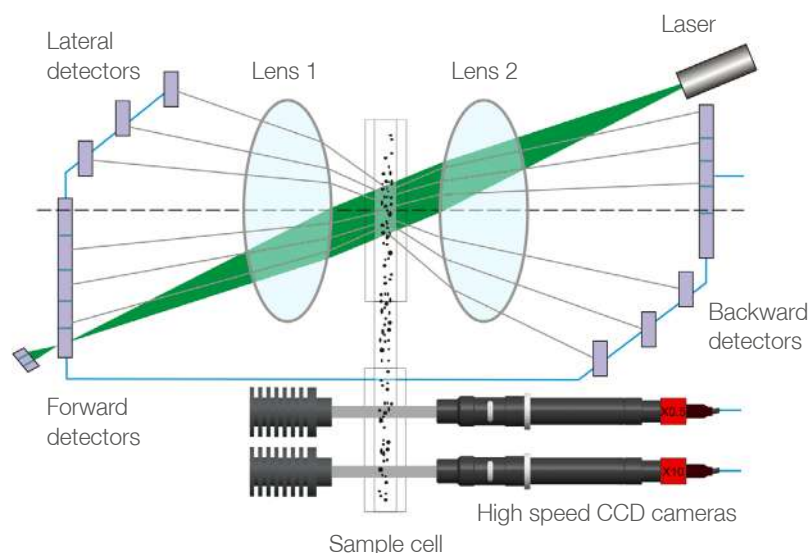

Bettersizer S3 Plus schematic diagram

Features and benefits:

- **Measuring range:**
Particle size: 0.01 - 3500 µm
Particle shape: 2 - 3500 µm
- **DLOIOS - Dual Lens and Oblique Incidence Optical System**
- **CCD camera technology:** Two CCD cameras with 0.5X and 10X magnification photograph and evaluate more than 10,000 particles per minute
- **Refractive index measurement:** For materials with unknown refractive index
- **Ease of use:** SOP, automatic alignment, automatic circulation and dispersion system
- **Powerful software:** Calculate aspect ratio, L/D, circularity and perimeter

DLOIOS:

DLOIOS is a new technology patented by Bettersize based on the Fourier optical system. Lens 2 converts the divergent laser beam into a parallel beam on the one hand. On the other hand, it allows the detection of backscattered light.

Using only one laser provides a continuous spread spectrum with a consistent wave length, oblique light incidence and this special structure enables detection in the angular range of 0.02° - 165°. DLOIOS technology guarantees reliable measurement of fine particles of 10 nm diameter.

Bettersizer S3

STATE-OF-THE-ART LASER PARTICLE SIZE ANALYZER

Bettersizer S3 represents the leading particle size analysis technology for wet dispersion solutions. The measuring range from 0.01 to 3500 µm meets the most stringent requirements of fundamental research, product development and process control applications. SOP and automatic circulation and dispersion system ease workload and improve use experience.

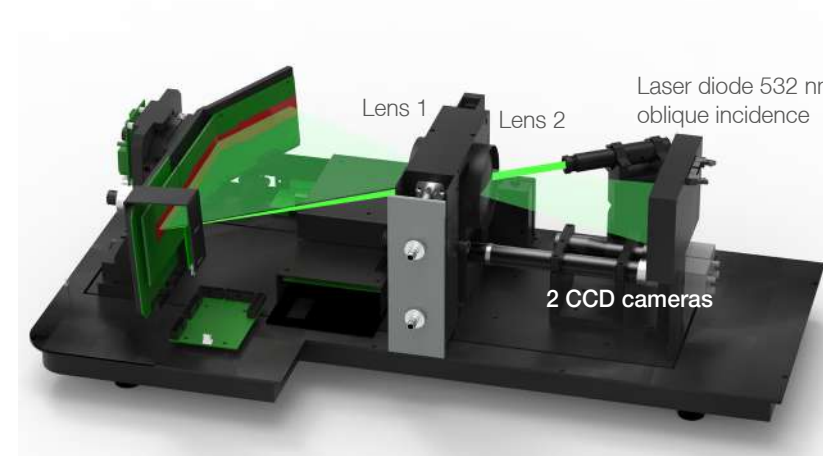

DLOIOS
(Dual Lens and Oblique Incidence Optical System)

Features and benefits:

- **Measuring range:**
Particle size: 0.01 - 3500 µm
Particle shape: 100 - 3500 µm
- **DLOIOS - Dual Lens and Oblique Incidence Optical System**
- **CCD camera technology:** One CCD camera with 120 fps and 1.3 MP
- **Refractive index measurement:** For materials with unknown refractive index
- **Ease of use:** SOP, automatic alignment, automatic circulation and dispersion system

Model	Bettersizer S3 Plus	Bettersizer S3
Particle size measuring range	0.01 - 3500 µm	0.01 - 3500 µm
Particle shape measuring range	2 - 3500 µm	100 - 3500 µm
Measuring principle	- Laser diffraction: DLOIOS - Dynamic Image: 0.5x and 10x lens	- Laser diffraction: DLOIOS - Dynamic Image: 0.5x lens
Dispersion system	Wet	Wet
Refractive index measurement	Yes	Yes

Bettersizer 2600

PARTICLE SIZE BY LASER DIFFRACTION WET AND DRY DISPERSION

The Bettersizer 2600 is a modern particle size analyzer that works under the principles of laser diffraction methods and conforms to the ISO 13320 standard.

The intelligent combination of the two traditional devices – Fourier and inverse Fourier – accurately measures fine and coarse particles even over a wide particle size distribution.

For dispersion, Bettersizer 2600 offers normal or small volume wet and dry modules. The smart modular design completes the conversion in seconds.



Bettersizer 2600 (Wet and Dry)

Features and benefits:

- **Measuring range:**
0.02 - 2600 μm (wet);
0.1 - 2600 μm (dry)
- **Dispersion:** Wet and/or Dry
- **Optical system:** Fourier and inverse Fourier optical system
- **Repeatability:** ≤0.5% (wet); ≤1% (dry) (GBRM D50)
- **Accuracy:** ≤0.5% (wet); ≤1% (dry) (GBRM D50)
- **Detectors:** 92 pieces (forward, lateral, backward)
- **Detection range:** 0.016° - 165°

Intuitive and powerful software:

- The simplest operation and clear interface
- Real-time mode for determining the optimal measurement conditions
- Working with SOP
- Fully automatic measurement routine with automatic calibration
- Automatic data backup and editable reports
- Direct conversion according to Fraunhofer and Mie evaluation model
- Automatic cleaning routine
- Convert from wet to dry dispersion with one click

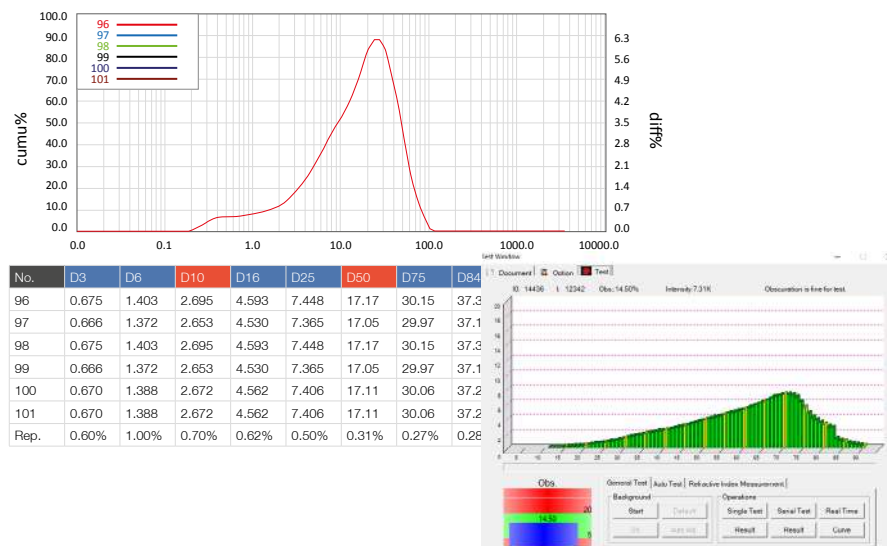

Wet and dry dispersion system:

In wet measurement, the particles are dispersed in a liquid medium in the dispersing module; and, if necessary, additionally dispersed by ultrasonic disperser.

Dry dispersion is used when dry powders or granules are to be measured without the use of solvent. During sample preparation, the sample is pre-dispersed by a vibrating transmission channel, falls into a channel and is conveyed by compressed air (venturi nozzle) through the closed, horizontal measuring cell. Dispersion is carried out by collision of the particles on the wall of container and with each other as well as by shearing.

The change between the dispersing modules requires only one handle.

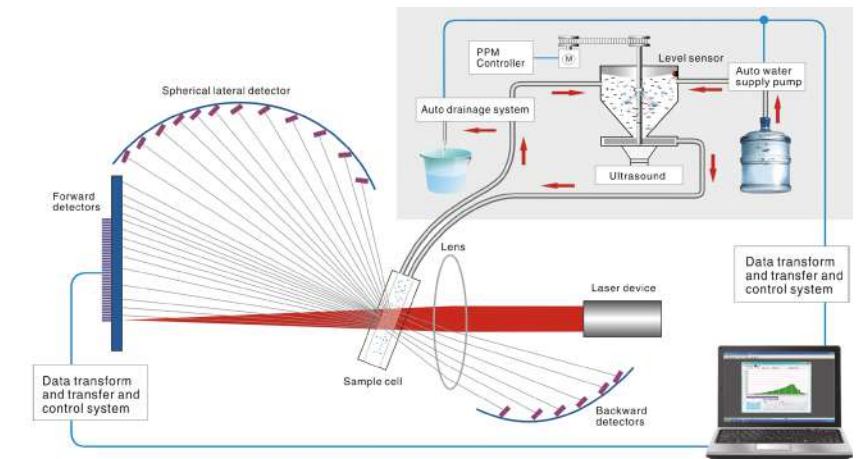
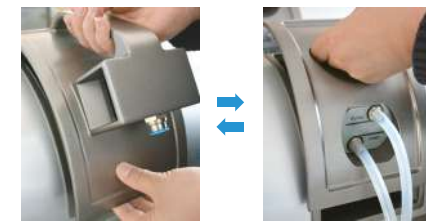

Wet dispersion system

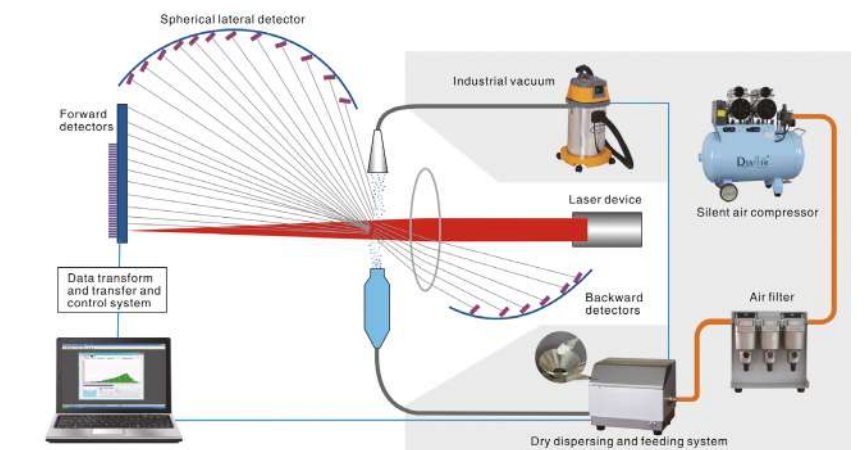

Dry dispersion system

Sample dispersion modules	BT-802	Small volume module	BT-902	BT-903
Dispersion system	Wet	Wet small volume	Dry	Dry small volume
Dispersion module				
Combine with main device				
Sample volume	600 ml	8 ml, 0.005 - 0.1 g	0.2 - 10 g	0.02 - 1 g
Automation	Fully automatic	Semiautomatic	Fully automatic	Fully automatic

RUGGED AND COMPACT LASER PARTICLE SIZE ANALYZER

The Bettersizer ST includes the patented DLOS (Dual Lens Optical System) which allows the ST to measure a wide particle size range. This technology increases system reliability and reduces cost by fully utilizing the capabilities of a single laser diode. The DLOS provides a compact design without resorting to folding optics that are susceptible to misalignment caused by vibrations often present in most industrial laboratories.

The ST incorporates 86 detectors to produce high resolution data from 0.1 to 1000 μm .



Features and benefits:

- **Measuring range:** 0.1 - 1000 μm
- **DLOS - Dual Lens Optical System**
- **SOP:** Standard Operation Procedure
- **Compact design** saves work space
- **Repeatability:** $\leq 1\%$ (GBRM D50)
- **Accuracy:** $\leq 1\%$ (GBRM D50)
- **Detectors:** 86 pieces (forward, backward)

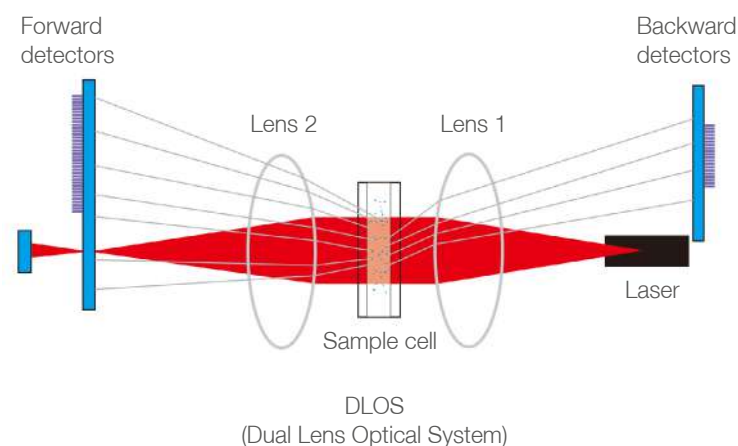

DLOS:

The DLOS (Dual Lens Optical System) detects both the forward and backscatter laser diffraction pattern. This breakthrough technology results in increased particle size measurement range without the added cost of a second light source. This single laser design provides for higher accuracy due to a consistent wavelength throughout the full measurement range.

NANOPARTICLE SIZE ANALYZER

The Nanoptic 90 Plus nanoparticle size analyzer is an optical detection system newly designed to measure the particle size and size distribution of nanoparticles.

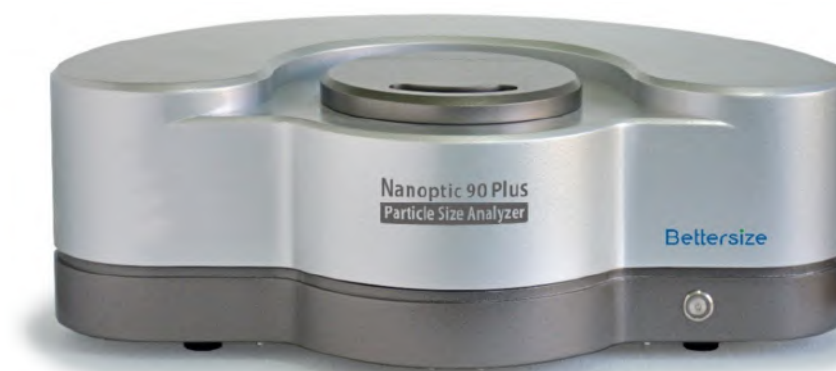

Nanoptic 90 Plus

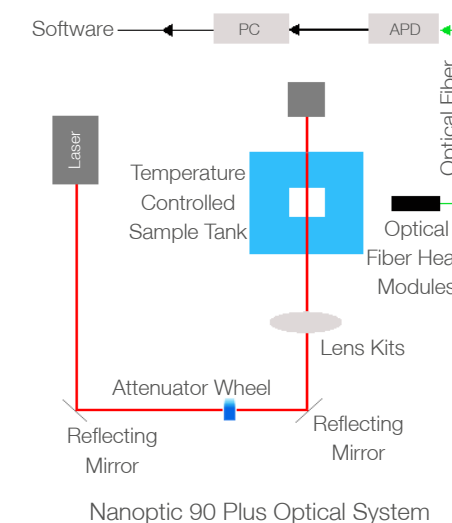

Features and benefits:

- **Measuring range:** 0.4 nm – 9 μm
- **Testing speed:** ≤ 5 minutes per test
- **Small quantity of sample required:** 40 μl and 1 ml
- **Temperature control range:** $-10^{\circ}\text{C} - 110^{\circ}\text{C} \pm 0.1^{\circ}\text{C}$
- **Repeatability:** $\leq 1\%$
- **Accuracy:** $\leq 1\%$
- **Scattering angle:** 90°
- **Detector:** APD

DLS:

Dynamic light scattering is applied in the Nanoptic 90 Plus system. The sample dispersion is filled in the sample cell and irradiated by a 671nm laser beam. An optical fiber connected with APD is aligned at 90° to detect the fluctuation of the scattering intensity caused by the Brownian motion of the sample. The autocorrelation calculation of the sample is performed by the correlator results in correlation function. By applying mathematical algorithms, the diffusion coefficient of the particle can be obtained. The particle size and size distribution of the sample can be calculated by Stokes-Einstein equation.

Application fields:

Particle size and distribution of polymers, colloids, self-assembled micelles, biomacromolecules, proteins, peptides, antigens, antibodies, nano metal/non-metal particles.

Study on polymerization process and reaction mechanism.

Study on kinetics of self-assembly and other processes of polymerization and depolymerization of macromolecules.

Research on the temperature trend of a system, such as temperature sensitive colloid PNIPAM.

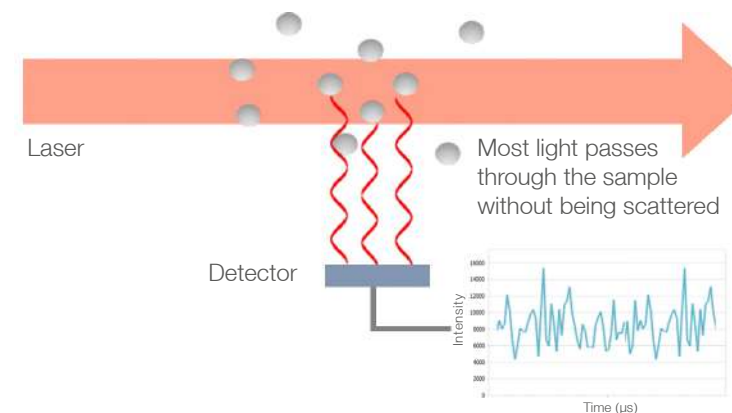

Bettersizer 2000S

REAL-TIME SPRAY PARTICLE SIZE ANALYZER

The Bettersizer 2000S is designed for particle size analysis of sprays containing 1 to 2000 µm droplets or solid particles. The width-adjustable measurement area allows the Bettersizer 2000S to flexibly adapt to the requirements of customers in challenging technical applications in the laboratories or pilot plants.

Features and benefits:

- **Measuring range:** 1 - 2000 µm
- **Width-adjustable measurement area**
- **Repeatability:** <3% (GBRM D50)
- **Accuracy:** <3% (GBRM D50)
- **Test speed:** ≤10 seconds
- **Sealing level:** IP65
- **Lens protection:** Protective groove device with oblique angle
- **Interface mode:** USB 2.0 or 3.0
- **Flexible installation** based on the site environment and customer needs.



BT-Online1

ROBUST ONLINE PARTICLE SIZE ANALYZER

BT-Online1 is a robust online particle size analyzer for real-time monitoring and quality control in the powder manufacturing process. Based on SOP, BT-Online1 automatically samples, measures, recovers and processes data directly from the powder pipeline and provides 24-hour particle size detection and control for a variety of dry powder production lines.

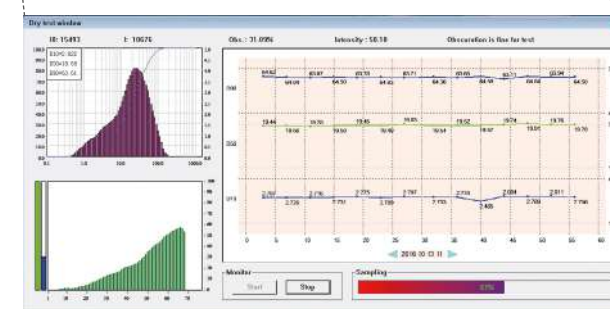
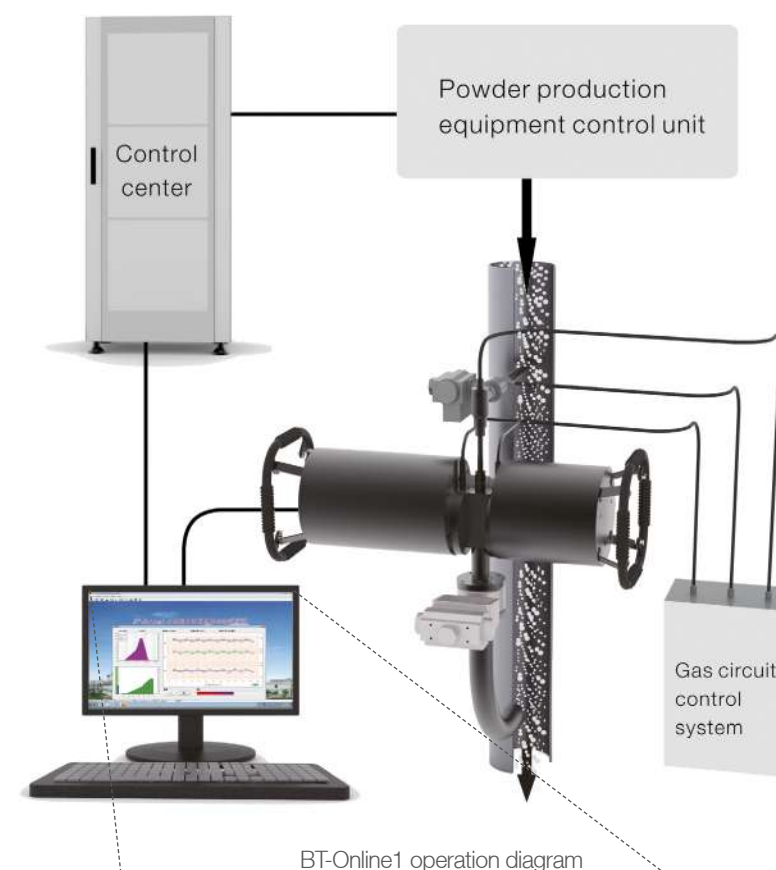

Features and benefits:

- **Measuring range:** 0.1 - 1000 µm
- **Repeatability:** ≤3% (GBRM D50)
- **Accuracy:** ≤3% (GBRM D50)
- **SOP:** Standard Operation Procedure
- **Detectors:** 68 pieces
- **Test speed:** ≤1 min
- High-performance semiconductor laser with long lifespan
- Automatic Alignment

Safe and robust online monitoring:

The BT-Online1 features power interruption and overvoltage protection to automatically shut down the sequence under abnormal operating conditions to protect the lens from contamination. Its rugged design helps to combat harsh and electromagnetic interference.



BT-Online1 production line

BeVision D2

DYNAMIC IMAGE ANALYZER DRY DISPERSION

The BeVision D2 is a microscopic image particle size and shape analyzer for non-destructive measurement of coarse particles and millimeter range powder materials. BeVision D2's high speed CCD camera and multi-threaded software quickly identify particles and obtains stable and accurate measurement results.



Features and benefits:

- **Measuring range:** 30 - 10,000 μm (dry)
- **Optimized software:** Identify 10,000 particles per minute. Automatic recognition of agglomerated powder
- **Analysis parameters:** Particle size distribution, D100, aspect ratio, circularity and radius-thickness ratio
- **High-speed CCD camera:** 120 images per second, microsecond exposure time, avoid trailing in moving particles
- **Sampler:** Dry sampler using electromagnetic vibration feed, gravity-driven dispersion, suitable for coarse and agglomerated particles

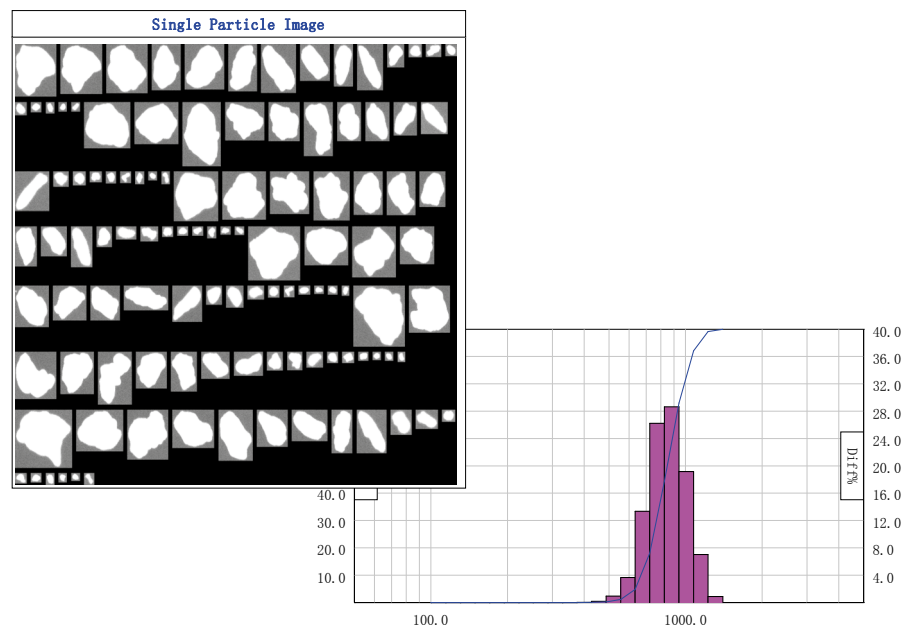

BeVision W1

DYNAMIC IMAGE ANALYZER WET DISPERSION

The BeVision W1 is a high resolution dynamic image particle size and shape analyzer. Based on sheath flow theory, BeVision W1 captures each particle and delivers accurate image data.

Features and benefits:

- **Measuring range:** 4 - 400 μm (wet)
- **Analysis parameters:** Particle size distribution, D100, aspect ratio, circularity and radius-thickness ratio
- **Sheath flow theory:** Ensure that each particle passes sequentially through the focal plane of the cell, eliminating particle overlap and defocus
- **Optimized software:** Identify 10,000

particles per minute. Automatic recognition of agglomerated powder improves accuracy



BeVision M1

CLEANLINESS ANALYSIS EXPERT

The BeVision M1 is an automated image scanning system for filter paper cleanliness analysis. Equipped with metallurgical microscope, programmable motorized platform, autofocus function and high resolution CCD camera, BeVision M1 can capture and recognize each individual particle and automatically stitch the images to a panorama.



Features and benefits:

- **Measuring range:**
Particle size and shape: 1 - 10,000 μm
- **Panorama:** Systematically steps and scans defined areas, capturing images at every step interval. The software seamlessly stitches captured images into a high resolution panorama
- **Particle size and shape analysis:** Particle size distribution, D100, aspect ratio, circularity and radius-thickness ratio

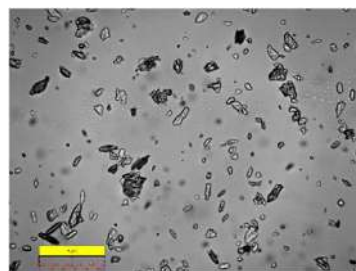

Agglomerated particles

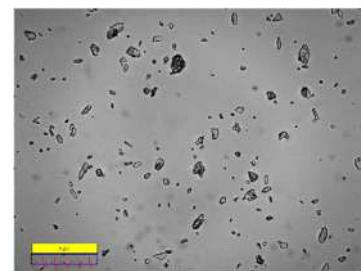

Depolymerized particles

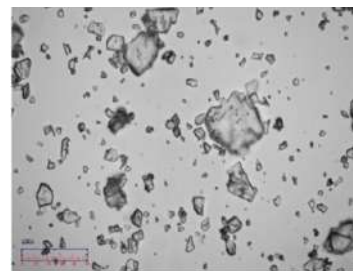

Flaky particles

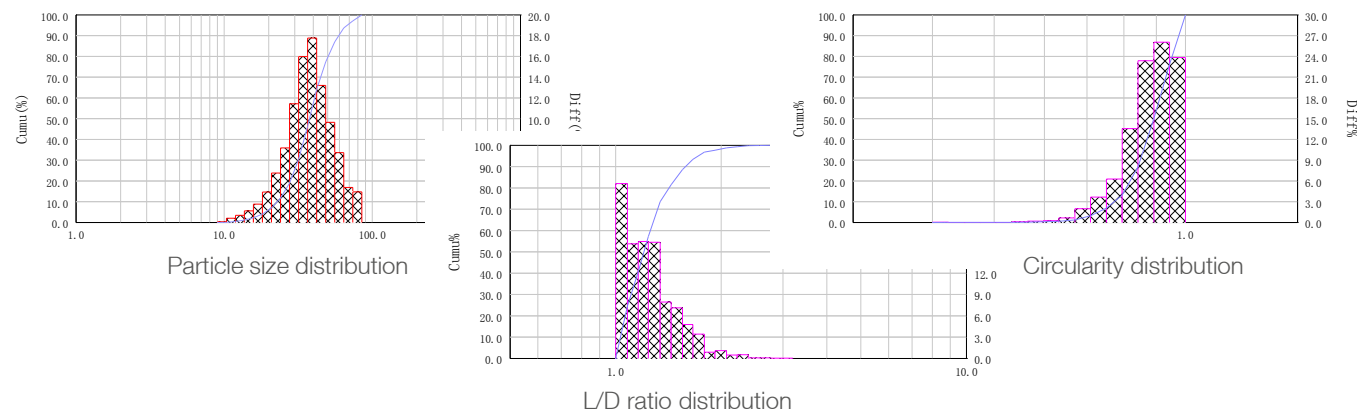

BeVision S1

CLASSIC DYNAMIC IMAGE ANALYZER

BeVision S1 uses the latest software particle image processing technology for traditional microscopy imaging methods, providing a variety of particle parameters and distributions, including particle size, L/D ratio, circularity, area, etc. BeVision S1 is widely used for particle shape observation and analysis fields such as abrasives and pharmaceutical development, manufacturing and quality control.



Features and benefits:

- **Measuring range:**
Particle size and shape: 1 - 3000 μm
- **Max magnification:** 4000 times
- **Repeatability:** $\leq 3.0\%$ (GBRM D50)
- **Accuracy:** $\leq 3.0\%$ (GBRM D50)
- **CCD camera:** 5 MP
- **Analysis parameters:** Particle size distribution, D100, aspect ratio, circularity and radius-thickness ratio

Automatically split connected particles

When using the image method, the aggregated particles have a large influence on the measurement results. Unlike the usual manual splitting, the BeVision S1's automatic segmentation feature helps you get accurate particle information by quickly and accurately separating particles.

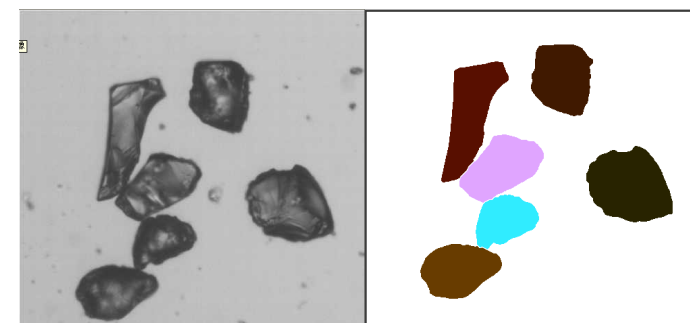

Precise calibration

The actual size of the particles can be accurately calibrated by the scale ruler.

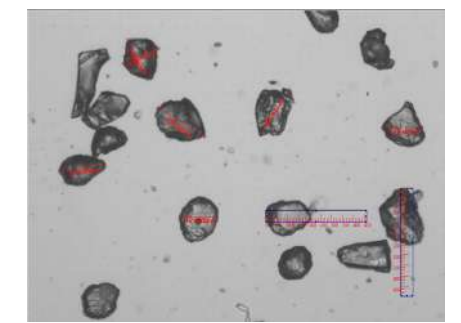

PowderPro A1

AUTOMATIC POWDER CHARACTERISTICS TESTER

PowderPro A1 automatically analyse powder characteristics such as angle of repose, angle of fall, angle of spatula, bulk density and tapped density of a variety of powder materials. Applied image technology automatically controlled by PC, PAD or Android App, PowderPro A1 is an essential tool for research and evaluation of powder materials.

PowderPro A1 measures:

- Angle of Repose and Fall
- Angle of Spatula (Flat Plate Angle)
- Bulk and Tapped Densities
- Dispersibility
- Voidage and Cohesion

PowderPro A1 calculates:

- Angle of Difference
- Compressibility
- Uniformity
- Flowability Index
- Floodability Index
- Sieve size: 45 - 2000 µm

Conformity:

- ASTM D6393-08/D6393-14
- ISO 3953: 1993
- USP32-NF27<616>
- EP7.0 07/2010: 20934E

Key benefits:

• Measure angles with image method
Photographs were taken using high-definition CCD imaging technology. Parameters such as angle of repose, angle of fall and angle of spatula are obtained in a fast and easy way with high precision and good repeatability through the unique image recognition and processing technology.

• Automatic control technology
Fully automatic PC or mobile control ensures easy usage and operation. Accurate and reliable test results are obtained by SOP mode for standardized testing process.

• Data communication
The electronic scale is connected to the instrument and the weight data is automatically transferred to the system for data processing and calculation of results.

• Tapped density technology
The tapped density is achieved through the perfect combination of variable frequency and rotary vibration technology. The vibration frequency of 50 to 300 times per minute can be continuously adjusted; vibration amplitude of 3 or 14 mm can be selected. During the vibration process, the cylinder is in a uniform rotation state, ensuring the surface and horizontal powder surface, and improving the accuracy of the reading.



PowderPro M1

MANUAL POWDER CHARACTERISTICS TESTER

PowderPro M1 is the basic version of PowderPro A1. It can perform almost the same measurement and analysis of the PowderPro A1 through a manual process. The PowderPro M1 is widely used in education.



PowderPro M1 measures:

- Angle of Repose and Fall
- Angle of Spatula (Flat Plate Angle)
- Bulk and Tapped Densities
- Dispersibility
- Voidage and Cohesion
- Angle of Slide
- Hall Flow Rate (customized)

PowderPro M1 calculates:

- Angle of Difference
- Compressibility
- Uniformity
- Flowability Index
- Floodability Index

Conformity:

- ASTM D6393-08/D6393-14
- ISO 3953: 1993
- USP32-NF27<616>
- EP7.0 07/2010: 20934E

Measure angle of repose

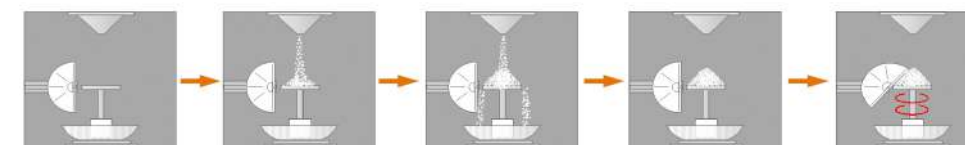

Measure bulk density and tapped density

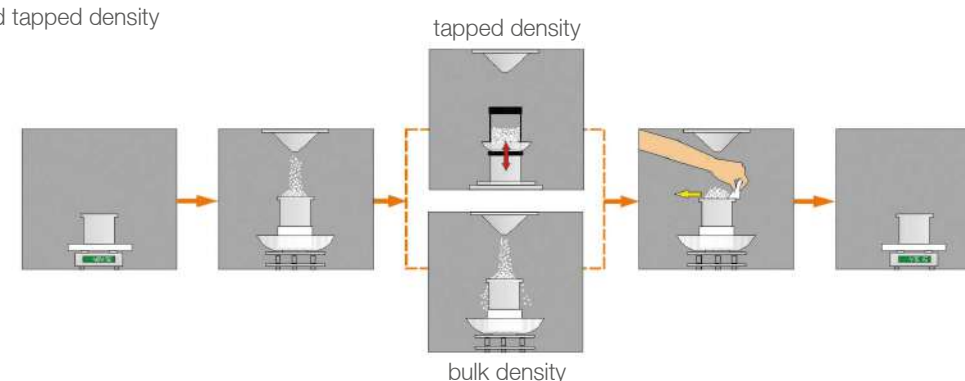

BeDensi series / HFlow-1 / BT-50

BEDENSI T1 / T2 / T3

TAPPED DENSITY METER

The BeDensi T series consists of BeDensi T1, T2, and T3, which has one, two, three cylinders respectively. T2 and T3 can simultaneously measure the tapped density of 2 or 3 powder samples.

BeDensi T series is compliant per international standard ISO3953: 1993 and the United States Pharmacopeia for drug tapped density testing.



BEDENSI B1-S

BULK DENSITY METER (FOR METAL POWDER)

The BeDensi B1-S bulk density meter uses the Scott capacity method to measure the bulk density of various metal powders. The manufacturing standard of BeDensi B1-S is in accordance with ISO 3923/2.



BEDENSI B1

BULK DENSITY METER (EXCEPT METAL POWDER)

The BeDensi B1 bulk density meter adopts the natural deposition method. Fully in accordance with GB / T16913.3-1997 - Part III: Determination of bulk density.



HFLOW-1

FLOWABILITY TESTER (FOR METAL POWDER)

HFlow-1 evaluates the flowability of metal powders by testing the capability of the sample to flow through a 2.5 mm standard funnel.

The HFlow-1 Hall Flow meter is designed and manufactured based on the ISO4490-2008 standard.

Services and Support

Quality is at the core of the way we do business, and is constantly verified by our customers and partners. The latest technology and strict quality control system enable our instruments to operate trouble-free on average for more than 1,000 days.

Over past decades, Bettersize has provided every product user analysis demonstrations, installation and training, software upgrade, 10-year supply of spare parts, and maintenance services. We also offer regular workshop of maintenance and repair services to our business partners and global distributors.



Bettersizer S3 Plus Particle Size Analysis Report

Range : 0.01um - 3500um

Sample : DUKE-5um	Number : 1#	Sample Owner : duke
Operator : LC	Time : 2018-05-15 10:15:40	Measured By : bettersize
Method : Laser	Preparation:	Medium : Water
Dispersant :	Ultrasound:	Stirring:
Optical : Mie	Mode : 8.0 - Multipeak	Distribution : Volume
Particle RI : 1.59-0i	Medium RI : 1.333	Remark :

D[4,3] : 5.066 um	D[3,2] : 4.817 um	SSA : 403.8 m ² /kg	OBS. : 2.57 %
D[2,1] : 4.549 um	D[1,0] : 4.251 um	SPAN : 0.562	Residual : 3.748 %
D03 = 3.136 um	D06 = 3.510 um	D10 = 3.733 um	D16 = 4.025 um
D25 = 4.308 um	D50 = 4.999 um	D84 = 6.177 um	D90 = 6.543 um

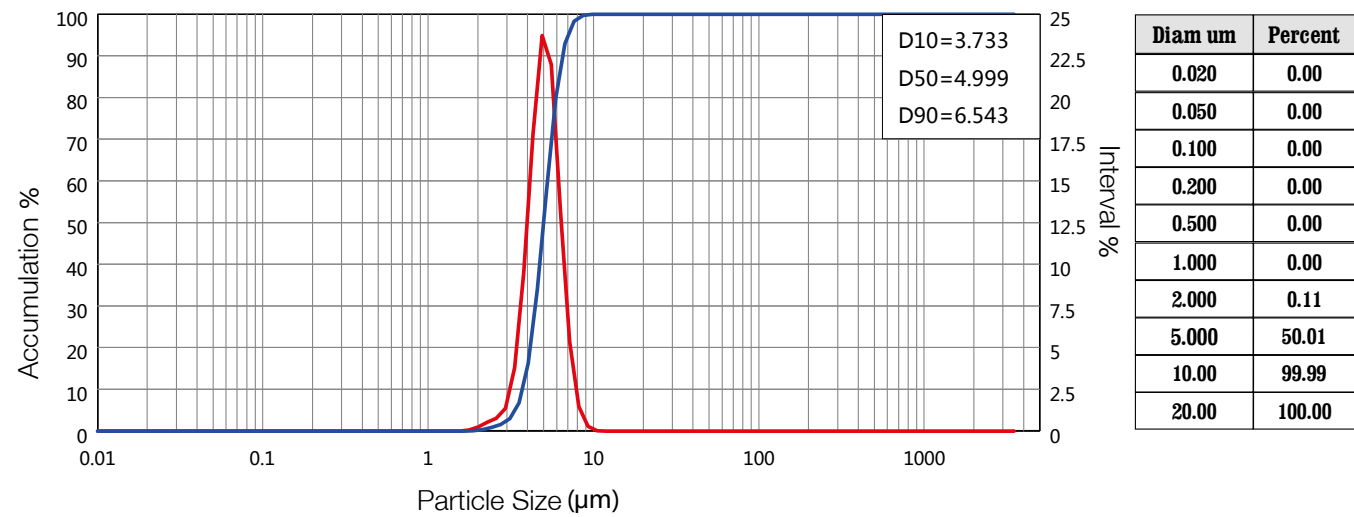

Diam um	Diff%	Cum%	Diam um	Diff%	Cum%	Diam um	Diff%	Cum%	Diam um	Diff%	Cum%
0.010-0.011	0.00	0.00	0.243-0.276	0.00	0.00	5.916-6.721	13.18	92.90	143.8-163.4	0.00	100.00
0.011-0.012	0.00	0.00	0.276-0.313	0.00	0.00	6.721-7.636	5.35	98.25	163.4-185.7	0.00	100.00
0.012-0.014	0.00	0.00	0.313-0.356	0.00	0.00	7.636-8.676	1.46	99.71	185.7-211.0	0.00	100.00
0.014-0.016	0.00	0.00	0.356-0.405	0.00	0.00	8.676-9.858	0.27	99.98	211.0-239.7	0.00	100.00
0.016-0.018	0.00	0.00	0.405-0.460	0.00	0.00	9.858-11.20	0.02	100.00	239.7-272.4	0.00	100.00
0.018-0.021	0.00	0.00	0.460-0.523	0.00	0.00	11.20-12.72	0.00	100.00	272.4-309.5	0.00	100.00
0.021-0.024	0.00	0.00	0.523-0.594	0.00	0.00	12.72-14.45	0.00	100.00	309.5-351.6	0.00	100.00
0.024-0.027	0.00	0.00	0.594-0.675	0.00	0.00	14.45-16.42	0.00	100.00	351.6-399.5	0.00	100.00
0.027-0.031	0.00	0.00	0.675-0.767	0.00	0.00	16.42-18.66	0.00	100.00	399.5-453.9	0.00	100.00
0.031-0.035	0.00	0.00	0.767-0.871	0.00	0.00	18.66-21.20	0.00	100.00	453.9-515.7	0.00	100.00
0.035-0.040	0.00	0.00	0.871-0.990	0.00	0.00	21.20-24.09	0.00	100.00	515.7-586.0	0.00	100.00
0.040-0.046	0.00	0.00	0.990-1.125	0.00	0.00	24.09-27.37	0.00	100.00	586.0-665.7	0.00	100.00
0.046-0.052	0.00	0.00	1.125-1.278	0.00	0.00	27.37-31.10	0.00	100.00	665.7-756.4	0.00	100.00
0.052-0.059	0.00	0.00	1.278-1.452	0.00	0.00	31.10-35.33	0.00	100.00	756.4-859.4	0.00	100.00
0.059-0.067	0.00	0.00	1.452-1.650	0.00	0.00	35.33-40.14	0.00	100.00	859.4-976.4	0.00	100.00
0.067-0.077	0.00	0.00	1.650-1.875	0.05	0.05	40.14-45.61	0.00	100.00	976.4-1109	0.00	100.00
0.077-0.087	0.00	0.00	1.875-2.130	0.23	0.28	45.61-51.82	0.00	100.00	1109-1260	0.00	100.00
0.087-0.099	0.00	0.00	2.130-2.420	0.52	0.80	51.82-58.87	0.00	100.00	1260-1432	0.00	100.00
0.099-0.113	0.00	0.00	2.420-2.750	0.75	1.55	58.87-66.89	0.00	100.00	1432-1627	0.00	100.00
0.113-0.128	0.00	0.00	2.750-3.124	1.36	2.91	66.89-76.00	0.00	100.00	1627-1848	0.00	100.00
0.128-0.145	0.00	0.00	3.124-3.550	3.80	6.71	76.00-86.35	0.00	100.00	1848-2100	0.00	100.00
0.145-0.165	0.00	0.00	3.550-4.033	9.53	16.24	86.35-98.11	0.00	100.00	2100-2386	0.00	100.00
0.165-0.188	0.00	0.00	4.033-4.583	17.79	34.03	98.11-111.4	0.00	100.00	2386-2711	0.00	100.00
0.188-0.214	0.00	0.00	4.583-5.207	23.71	57.74	111.4-126.6	0.00	100.00	2711-3080	0.00	100.00
0.214-0.243	0.00	0.00	5.207-5.916	21.98	79.72	126.6-143.8	0.00	100.00	3080-3500	0.00	100.00



Bettersize

BETTER PARTICLE SIZE SOLUTIONS

Dandong Bettersize Instruments Ltd.

Website: www.bettersizeinstruments.com

Email: info@bettersize.com

Address: No. 9, Ganquan Road, Jinqun Industrial Park, Dandong, Liaoning, China

Postcode: 118009

Tel: +86-415-6163800

Fax: +86-415-6163800

The product information in this brochure is subject to change due to technical innovation and performance upgrade without notice. This brochure is only for reference. If there is any inconsistency in future, please adhere to the actual product instead. Bettersize instruments shall not be responsible for errors contained herein.

The Bettersize logo is trademark owned by Dandong Bettersize Instruments Ltd.